

# NIKA ZUPANC®

## *Pom Pon Chandelier*



DESIGN: NIKA ZUPANC | YEAR OF DESIGN: 2011 | PRODUCT CODE: LPPG11-01 | PRODUCTION: Handmade

#### DESCRIPTION:

Suspended lamp

#### MATERIALS:

laser cut aluminium - colored

#### TECHNICAL:

**CE** Input voltage of 220–240V ~50Hz/60Hz AC  
1x E27, 2x E27 or 3x E27

#### Preferred bulbs:

1. PHILIPS MASTER LED Spot 9,5W-75W E27 2700K PAR30 S 25D
2. OSRAM DULUX SUPERSTAR GLOBE 14W

CABLE LENGTH 4 m (10 m available on request)  
Steel Canopy

#### COLORS:



# NIKA ZUPANC®

## *Pom Pon Chandelier*

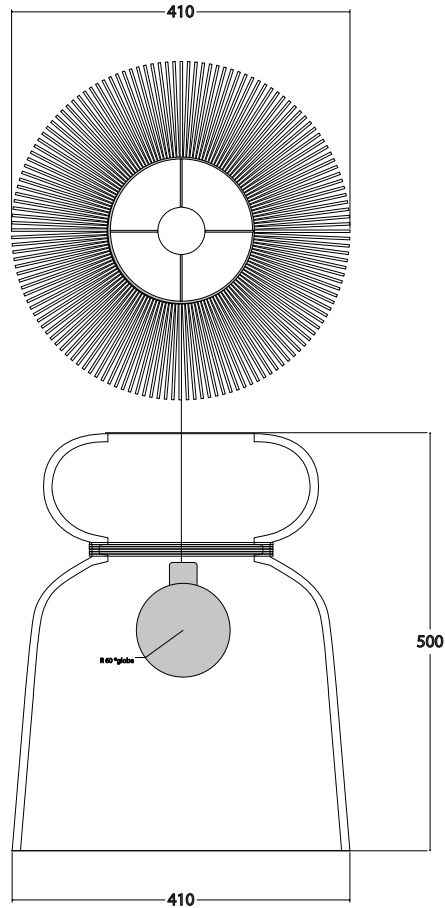

DESIGN: NIKA ZUPANC | YEAR OF DESIGN: 2011 | PRODUCT CODE: LPPG11-01 | PRODUCTION: Handmade

### DIMENSIONS

PRODUCT DIMENSIONS: 41 (W) x 50 (H) cm  
PRODUCT WEIGHT: 10 KG  
PACKAGING DIMENSIONS: 52 (W) x 47 (D) x 65 (H) cm  
PACKAGE WEIGHT: 12 KG

Packed in PP box with PE inserts

### CLEANING INSTRUCTIONS

The Lamp should first be cleaned with a dry cloth or duster to remove loose dust particles. Then, a good smear-free glass cleaner and cloth can be used to enhance the reflective sheen of the aluminium.